



## GANGWAYS



### PI 357 BIG FLASH LUX

Code MM BSZ PI357L



- Telescopic gangway completely automatic, combines the functions of gangway and crane
- Polished stainless steel structure
- Powder coated plate and polished piston
- Delivered with electro-hydraulic power pack and infrared remote control
- Supplied with automatic standard right stanchions and courtesy lights
- Footboard with teak grating

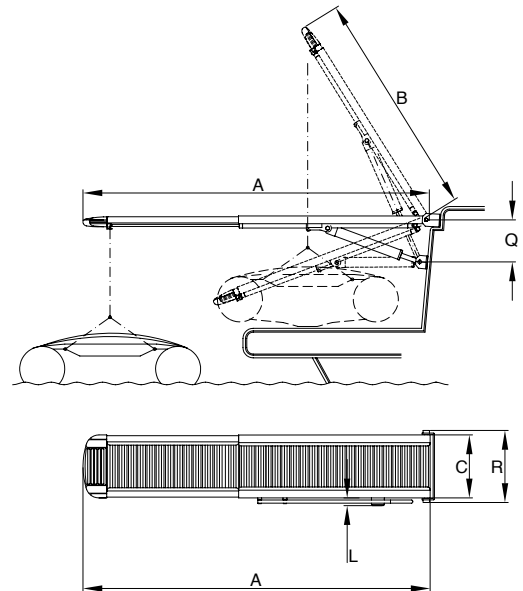

Lifting capacity kg	A mm	B mm	C mm	L mm	Q mm	R mm	Weight kg	Power supply volt
250 (300 Optional)	2300	1455	490	60	≥280	560	110 +12,5 power pack	12-24
250 (300 Optional)	2700	1750	490	60	≥280	560	140 +12,5 power pack	12-24

For your telephone orders ..... +39 0184 573346 press #1

E-mail orders and estimates ..... sales@mansuetomarine.it

Technical support ..... technical@mansuetomarine.it

Product Support & Data-Sheets ..... service@mansuetomarine.it

General Inquiries ..... info@mansuetomarine.it



**PI 357 BIG FLASH**

Code MM BSZ PI357

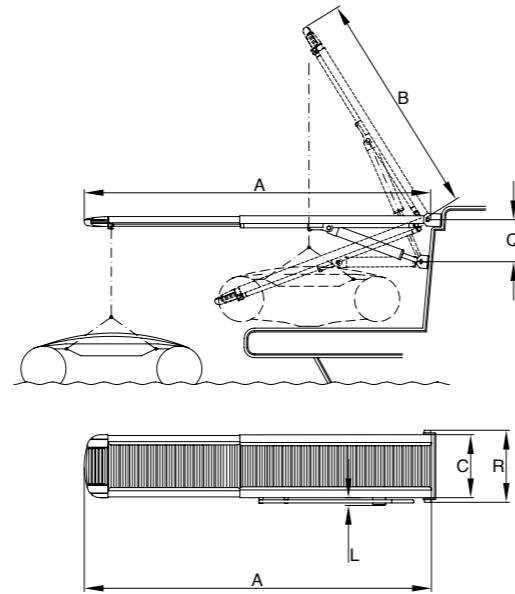

- Telescopic gangway completely automatic, combines the functions of gangway and crane
- Powder coated stainless steel structure
- Delivered with electro-hydraulic power pack and infrared remote control
- Supplied with automatic standard right stanchions and courtesy lights
- Footboard with teak grating

Lifting capacity kg	A mm	B mm	C mm	L mm	Q mm	R mm	Weight kg	Power supply volt
250 (300 Optional)	2300	1455	490	60	≥280	560	110 +12,5 power pack	12-24
250 (300 Optional)	2700	1750	490	60	≥280	560	140 +12,5 power pack	12-24



**PI 358 PREMIUM**

Code MM BSZ PI358

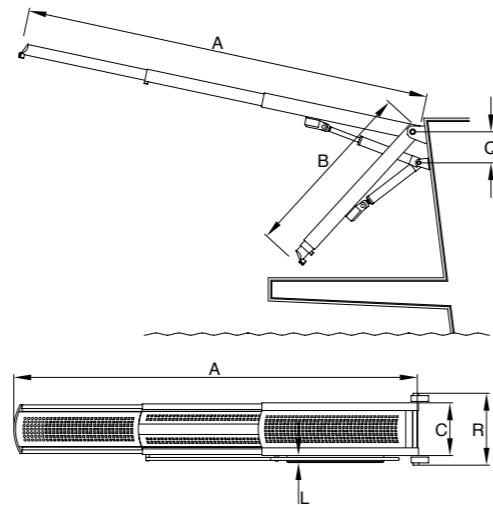

- Telescopic three stage gangway completely automatic
- Powder coated or polished stainless steel structure
- Delivered with electro-hydraulic power pack and infrared remote control
- Supplied with automatic standard right stanchions and courtesy lights
- Footboard with teak grating
- Polished piston in polished version

A mm	B mm	C mm	L mm	Q mm	R mm	Weight kg	Fixed bracket	Power supply volt
2390	1090	450	60	≥280	615	112	On aluminium	12-24
2980	1390	450	60	≥280	615	120	On aluminium	12-24
3560	1520	450	60	≥280	615	135	On aluminium	12-24
4060	1670	480	60	≥280	600	142	On steel	12-24
4560	1870	480	60	≥280	600	150	On steel	12-24
5100	2150	480	60	≥280	600	158	On steel	12-24



**PI 359 SPORT FLASH**

Code MM BSZ PI359

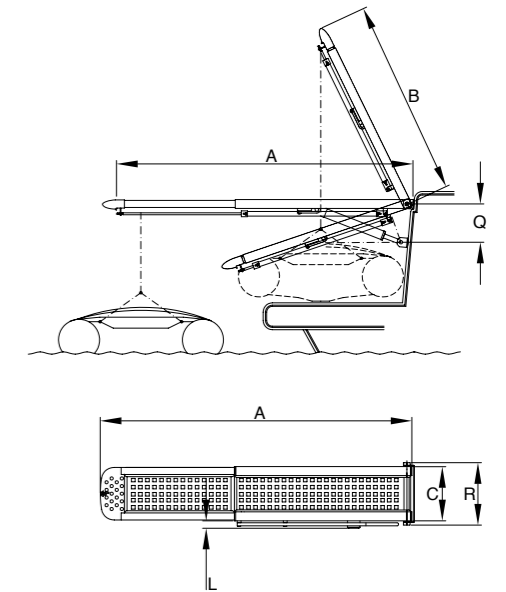

- Telescopic gangway completely automatic, combines the functions of gangway and crane
- Powder coated or polished stainless steel structure
- Delivered with electro-hydraulic power pack and infrared remote control
- Supplied with automatic standard right stanchions
- Footboard with teak grating

Lifting capacity kg	A mm	B mm	C mm	L mm	Q mm	R mm	Weight kg	Power supply volt
110	2040	1270	430	60	≥220	500	90 +12,5 power pack	12-24
110	2360	1450	430	60	≥220	500	100 +12,5 power pack	12-24
200	2660	1720	462	60	≥250	532	120 +12,5 power pack	12-24



**PI 369 SMART**

Code MM BSZ PI369

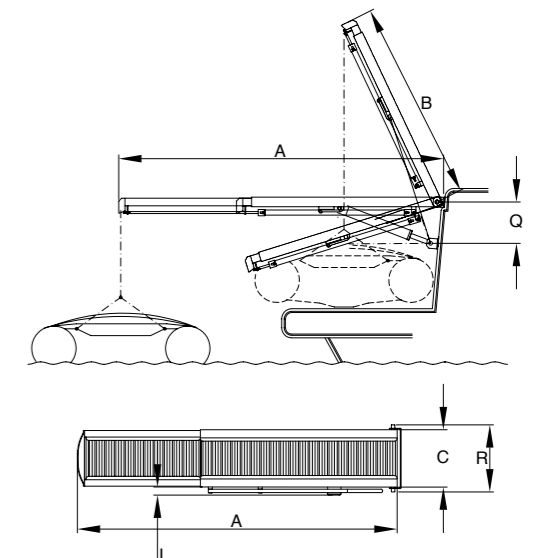

- Telescopic gangway completely automatic, combines the functions of gangway and crane
- Powder coated or polished stainless steel structure
- Delivered with electro-hydraulic power pack and infrared remote control
- Supplied with automatic standard right stanchions
- Grating footboard

Lifting capacity kg	A mm	B mm	C mm	L mm	Q mm	R mm	Weight kg	Power supply volt
110	1930	1150	430	60	≥220	500	65 +12,5 power pack	12-24
110	2250	1340	430	60	≥220	500	75 +12,5 power pack	12-24
200	2530	1600	462	60	≥250	532	85 +12,5 power pack	12-24





**PI 375 TEOREMA**

Code MM BSZ PI375

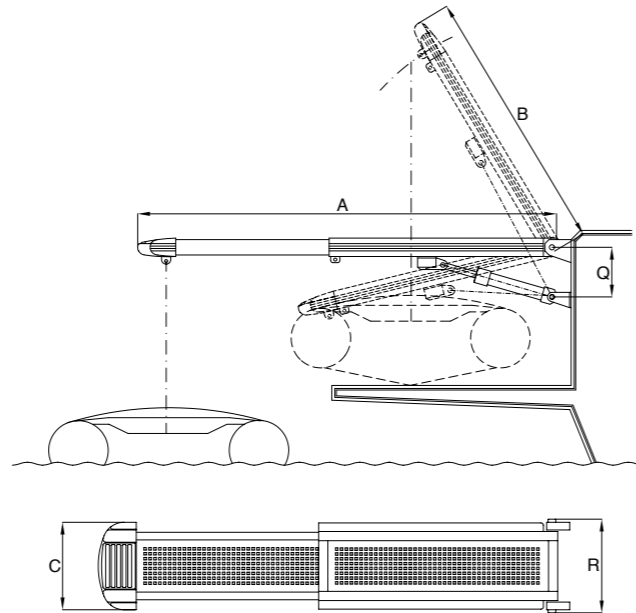

Lifting capacity kg	A mm	B mm	C mm	Q mm	R mm	Weight kg	Fixed bracket	Power supply volt
250-300	2300	1500	580	≥350	615	100	On coated aluminium	12-24
250-300	2700	1700	580	≥350	615	112	On coated aluminium	12-24
250-300	3100	1900	580	≥350	615	134	On coated aluminium	12-24
250-300	3500	2100	580	≥350	615	151	On coated aluminium	12-24
350-400	2300	1500	600	≥350	600	109	On coated steel	12-24
350-400	2700	1700	600	≥350	600	121	On coated steel	12-24
350-400	3100	1950	600	≥350	600	143	On coated steel	12-24
350-400	3600	2300	600	≥350	600	163	On coated steel	12-24

- Telescopic gangway completely automatic, combines the functions of gangway and crane
- Polished stainless steel structure
- Delivered with electro-hydraulic power pack and infrared remote control
- Supplied with automatic standard right stanchions and courtesy lights
- Footboard with teak grating



**PI 383 SUPER PREMIUM INSIDE**

Code MM BSZ PI383

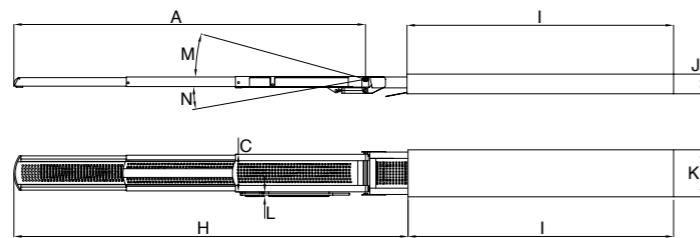

A mm	C mm	H mm	I mm	J mm	K mm	L mm	M (°)	N (°)	Optional	Weight kg	Power supply volt
4000	480	4000	2800	250	600	45	~ 15	~ 10	• Both side manual rigid handrail	355	12-24
4000	480	4500	3300	250	600	45	~ 15	~ 10	• Customised length	425	12-24
4500	480	5000	3400	250	600	45	~ 15	~ 10		450	12-24
4500	480	5500	3900	250	600	45	~ 15	~ 10		476	12-24
4500	480	6000	4400	250	600	45	~ 15	~ 10		550	12-24

- Telescopic retracting three stage gangway with teak carriage extension for the step passing
- Powder coated or polished stainless steel structure
- Delivered with electro-hydraulic power pack and infrared remote control
- Frontal backlit gems and courtesy lights
- Automatic right standard stanchions and manual left stanchions
- Footboard with teak grating

MANSUETO MARINE



**PI 376 ALBATROSS**

Code MM BSZ PI376

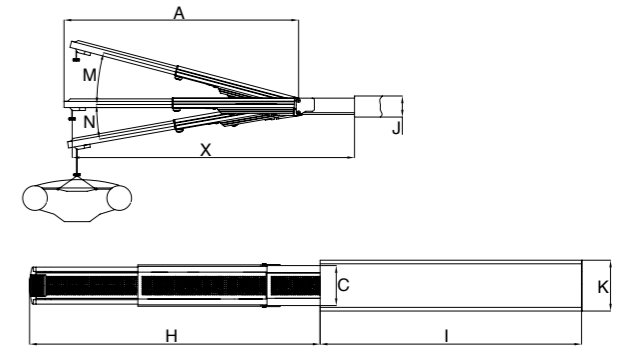

Lifting capacity kg	A mm	C mm	H mm	I mm	J mm	K mm	M (°)	N (°)	X mm	Power supply volt
400	3200	550	4000	3600	290	700	~ 15	~ 10	3880	12-24

- Telescopic retracting gangway, single or two stages, that combines the functions of gangway and crane
- Powder coated stainless steel structure
- Delivered with electro-hydraulic power pack and infrared remote control
- Manual stanchions and courtesy lights
- Footboard with teak grating

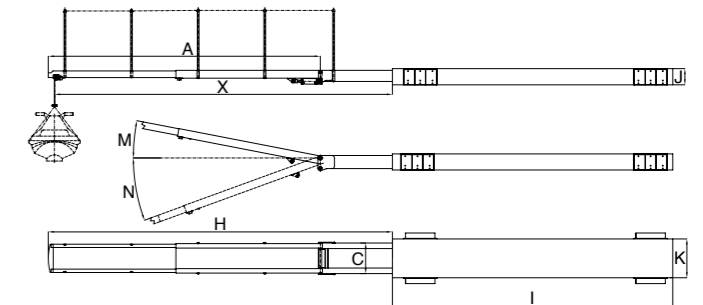

Lifting capacity kg	A mm	C mm	H mm	I mm	J mm	K mm	M (°)	N (°)	X mm	Power supply volt
300	4900	550	6200	5050	290	700	~ 11	~ 20	6080	24



**PI 387 SKIPPER**

Code MM BSZ PI387

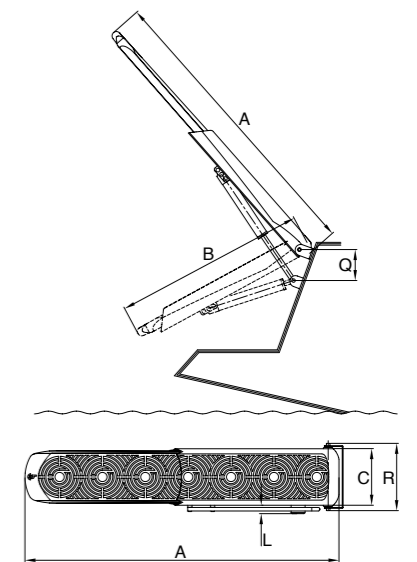

Lifting capacity kg	A mm	B mm	C mm	L mm	Q mm	R mm	Weight kg	Power supply volt
100	2220	1400	400	60	≥220	484	54 +12,5 power pack	12-24

- Telescopic gangway completely automatic for sails boat
- Combines the functions of gangway and crane
- Fibreglas or carbon structure
- Delivered with electro-hydraulic power pack and infrared remote control
- Supplied with automatic standard right stanchions

www.mansuetomarine.it



**PI 382 SPRINT - PI 382 SPRINT LUX**

Code MM BSZ PI382

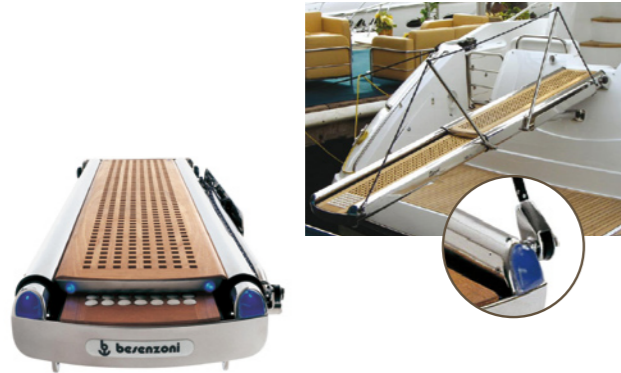

- Telescopic gangway completely automatic, combines the functions of gangway and crane
- Powder coated or polished stainless steel structure
- Polished plates and piston
- Delivered with electro-hydraulic power pack and infrared remote control
- Frontal backlit gems and courtesy lights
- Supplied with automatic standard right stanchions
- Footboard with teak grating

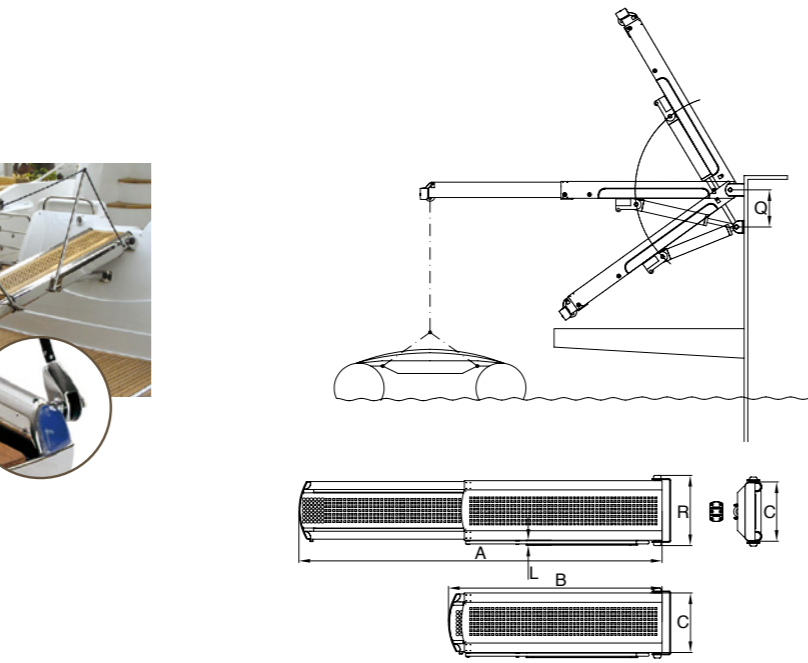

Lifting capacity kg	A mm	B mm	C mm	L mm	Q mm	R mm	Weight kg	Power supply volt
350	2540	1540	480	60	≥300	570	115 +12,5 power pack	12-24
350	2940	1740	480	60	≥300	570	127 +12,5 power pack	12-24



**PI 389**

Code MM BSZ PI389



- Telescopic gangway completely automatic, combines the functions of gangway and crane
- Powder coated and polished stainless steel structure
- Delivered with electro-hydraulic power pack and infrared remote control
- Frontal backlit gems and courtesy lights
- Supplied with automatic standard right stanchions
- Footboard with teak grating
- Polished plates and piston, in polished version

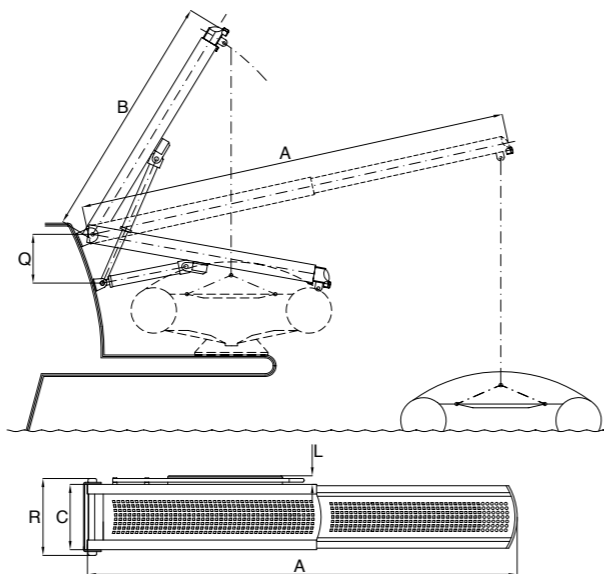

Lifting capacity kg	A mm	B mm	C mm	L mm	Q mm	R mm	Weight kg	Power supply volt
200	2500	1525	450	60	≥250	532	112 +12,5 power pack	12-24
200	3000	1725	450	60	≥250	532	125 +12,5 power pack	12-24

MANSUETO MARINE



**PI 457 BIG SMART**

Code MM BSZ PI457



- Telescopic gangway completely automatic, combines the functions of gangway and crane
- Powder coated or polished stainless steel structure
- Delivered with electro-hydraulic power pack and infrared remote control
- Supplied with automatic standard right stanchions
- Grating footboard

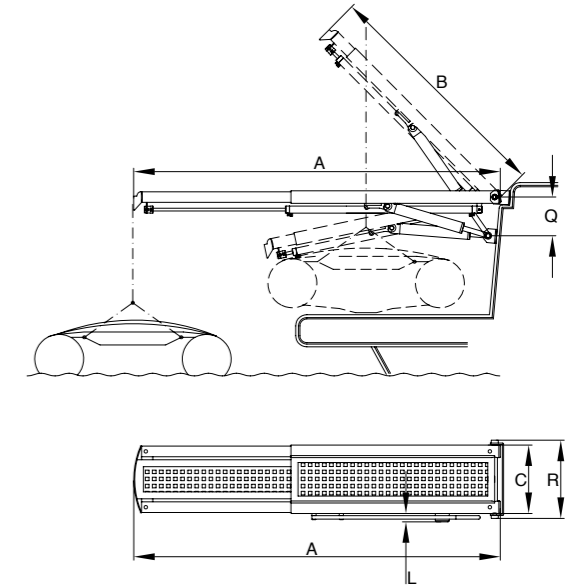

Lifting capacity kg	A mm	B mm	C mm	L mm	Q mm	R mm	Weight kg	Power supply volt
250 (300 Optional)	2250	1340	490	60	≥280	560	72 +12,5 power pack	12-24
250 (300 Optional)	2530	1600	490	60	≥280	560	82 +12,5 power pack	12-24



**PI 459 JUNIOR**

Code MM BSZ PI459



- Telescopic gangway completely automatic, combines the functions of gangway and crane
- Structure made of electro-polished stainless steel
- Delivered with electro-hydraulic power pack and infrared remote control
- Manual stanchions on the right side
- Full footboard

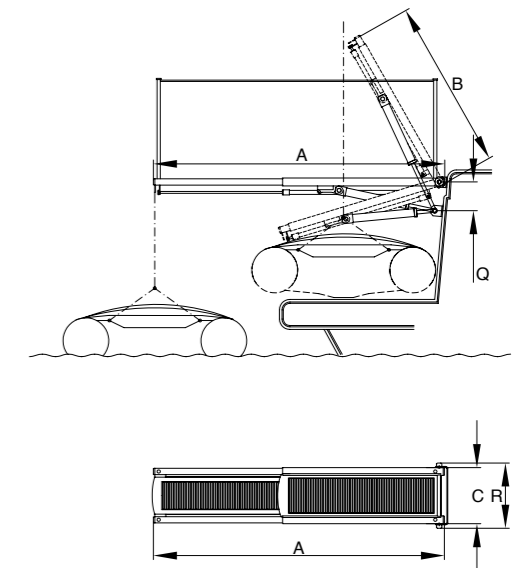

Lifting capacity kg	A mm	B mm	C mm	Q mm	R mm	Weight kg	Power supply volt
110	1910	1130	430	≥220	500	59 +12,5 power pack	12-24
110	2230	1320	430	≥220	500	73 +12,5 power pack	12-24
200	2510	1580	462	≥250	532	78 +12,5 power pack	12-24

www.mansuetomarine.it



**PI 460 LUXURY**

Code MM BSZ PI460

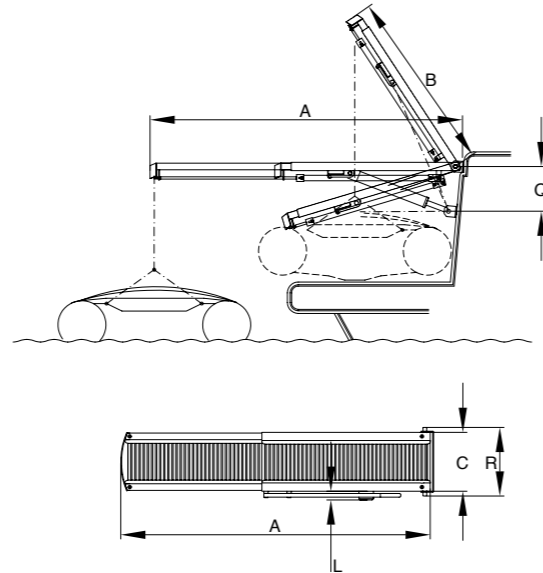

- Telescopic gangway completely automatic, combines the functions of gangway and crane
- Powder coated or polished stainless steel structure
- Delivered with electro-hydraulic power pack and infrared remote control
- Automatic stanchions on the right side
- Full footboard

Lifting capacity kg	A mm	B mm	C mm	L mm	Q mm	R mm	Weight kg	Power supply volt
110	1930	1150	430	60	≥220	500	65 +12,5 power pack	12-24
110	2250	1340	430	60	≥220	500	68 +12,5 power pack	12-24



**PI 482 BIG SPRINT - PI 482 BIG SPRINT LUX**

Code MM BSZ PI482

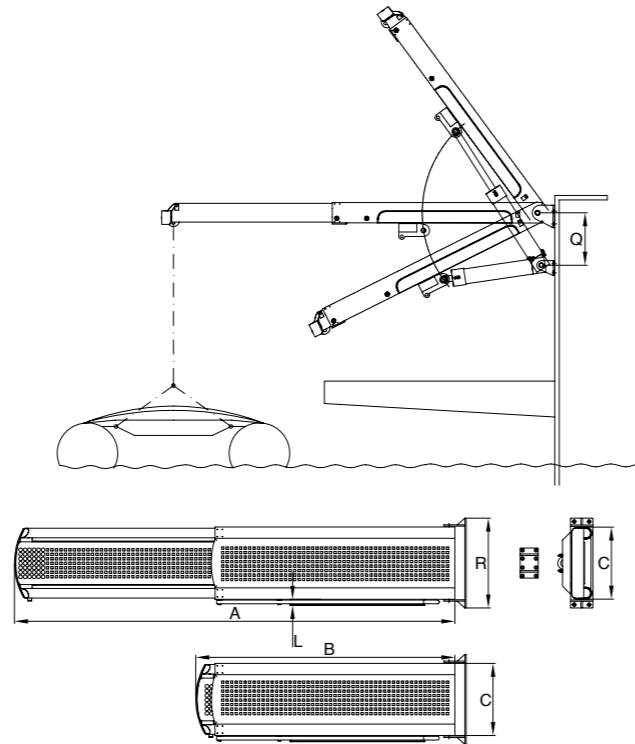

- Telescopic gangway completely automatic, combines the functions of gangway and crane
- Powder coated or polished stainless steel structure
- Polished plates and piston
- Delivered with electro-hydraulic power pack and infrared remote control
- Frontal backlit gems and courtesy lights
- Supplied with automatic standard right stanchions
- Footboard with teak grating

Lifting capacity kg	A mm	B mm	C mm	L mm	Q mm	R mm	Weight kg	Power supply volt
450	2540	1540	480	60	≥350	600	115 +12,5 power pack	12-24
450	2860	1670	480	60	≥350	600	127 +12,5 power pack	12-24
450	2940	1740	480	60	≥350	600	137 +12,5 power pack	12-24

MANSUETO MARINE



**PI 486 TITANIUM**

Code MM BSZ PI486

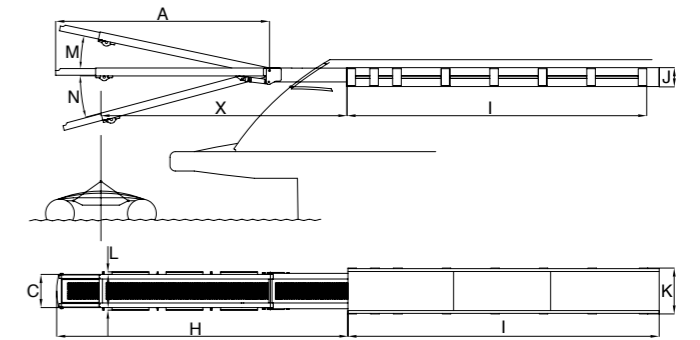

- Telescopic retracting two stages gangway
- Combines the functions of gangway and crane
- Titanium structure
- Delivered with electro-hydraulic power pack and infrared remote control
- Automatic rigid folding stanchions
- Courtesy lights and footboard with teak grating

Lifting capacity kg	A mm	C mm	H mm	I mm	J mm	K mm	L mm	M (°)	N (°)	R mm	Power supply volt
680	3700	588	5100	5450	330	804	45	~ 12	~ 15	4400	24



**PI 488 ERA**

Code MM BSZ PI488

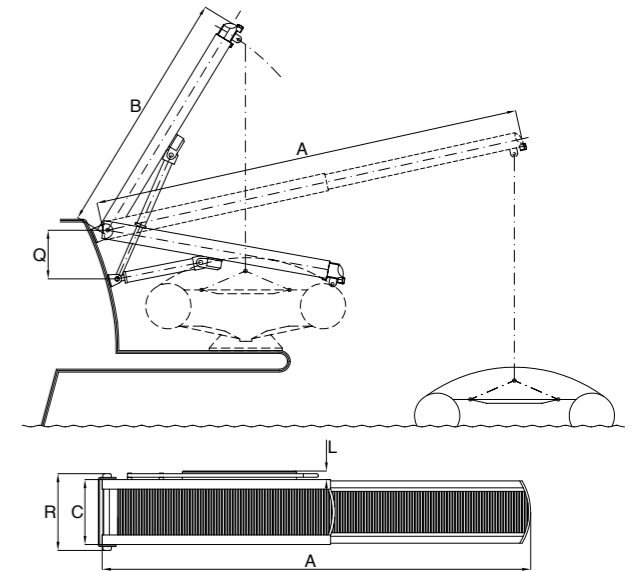

- Telescopic gangway completely automatic, combines the functions of gangway and crane
- Powder coated and polished stainless steel structure
- Powder coated plates and piston
- Delivered with electro-hydraulic power pack and infrared remote control
- Footboard with teak grating
- Full footboard

Lifting capacity kg	A mm	B mm	C mm	L mm	Q mm	R mm	Weight kg	Power supply volt
200	2500	1525	450	60	≥250	532	112 +12,5 power pack	12-24
200	3000	1725	450	60	≥250	532	125 +12,5 power pack	12-24

www.mansuetomarine.it





**EXTENDING BOX GANGWAY 1002**

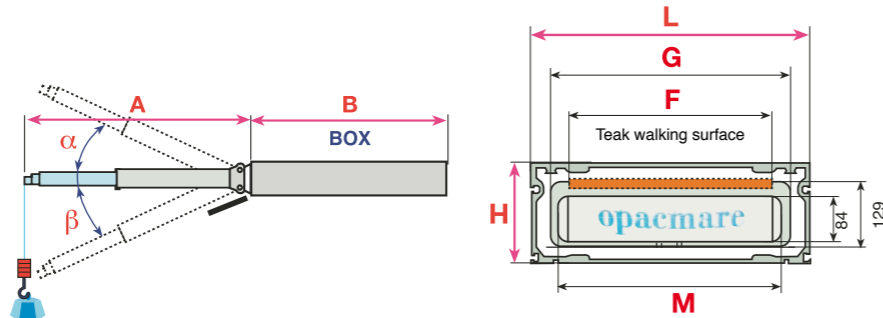

<b>L BOX</b>	510	550	590	660	710
<b>G</b>	390	430	470	550	600
<b>F teak</b>	260	300	340	410	460
<b>M</b>	355	395	435	515	555

Model Code	A mm	B mm	L mm	H mm	$\alpha$	$\beta$	Capacity optional kg	Weight kg
MM OPA 1002/25	2505	2140	550*	230	15°	15°	250	235
MM OPA 1002/29	2875	2340	550*	230	15°	15°	250	240
MM OPA 1002/35	3530	2650	550*	230	15°	15°	180	308
MM OPA 1002/40*	4040	3140	550*	230	15°	15°	-	418
MM OPA 1002/45*	4410	3480	550*	230	15°	15°	-	440
MM OPA 1002/50*	5040	3840	550*	230	15°	15°	-	461

\* Available with larger box optionals 510/590/660/710 mm. \* Manual stanchions only.



**EXTENDING BOX GANGWAY 1003**

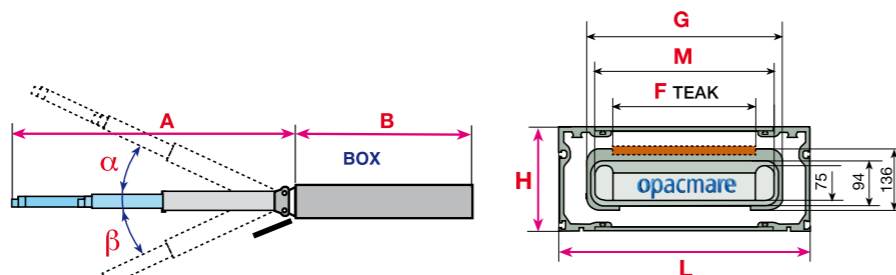

<b>L BOX</b>	510	550	590	660	710
<b>G</b>	390	430	470	550	600
<b>F teak</b>	260	300	340	410	460
<b>M</b>	355	395	435	515	555

Model Code	A mm	B mm	L mm	H mm	$\alpha$	$\beta$	Capacity optional kg	Weight kg
MM OPA 1003/33	3260	2140	550*	230	15°	15°	200	240
MM OPA 1003/36	3580	2340	550*	230	15°	15°	300	258
MM OPA 1003/38	3820	2460 2480	550* 710	230	15°	15°	-	275 293
MM OPA 1003/41	4100	2660	550*	230	15°	15°	-	300
MM OPA 1003/45	4500	2800	550*	230	15°	15°	-	384
MM OPA 1003/50*	5000	3200	550*	230	15°	15°	-	430

\* Available with larger box optionals 510/590/660/710 mm. \* Manual stanchions only.



**EXTENDING BOX GANGWAY 1022**

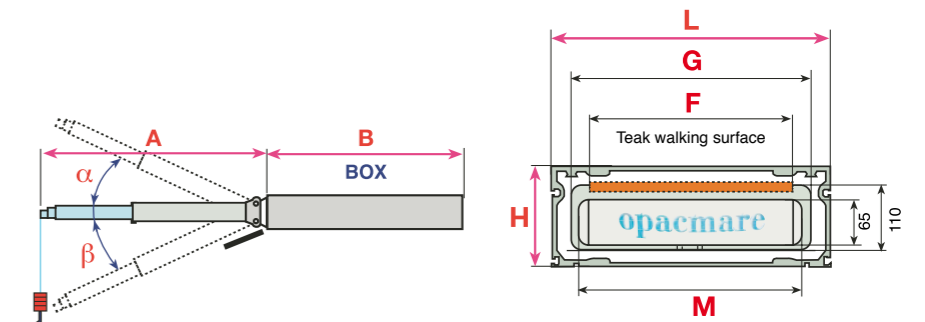
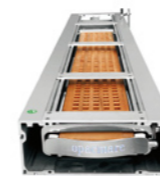

<b>L BOX</b>	510	550	590	710
<b>G</b>	389	429	469	598
<b>F teak</b>	260	300	340	460
<b>M</b>	356	396	434	556

Model Code	A mm	B mm	L mm	H mm	$\alpha$	$\beta$	Capacity optional kg	Weight kg
MM OPA 1022/33	3300	2620	550*	210	20°	15°	150	258

\* Available with larger box optionals 510/590/710 mm.



**ROTATING BOX GANGWAY 1202**

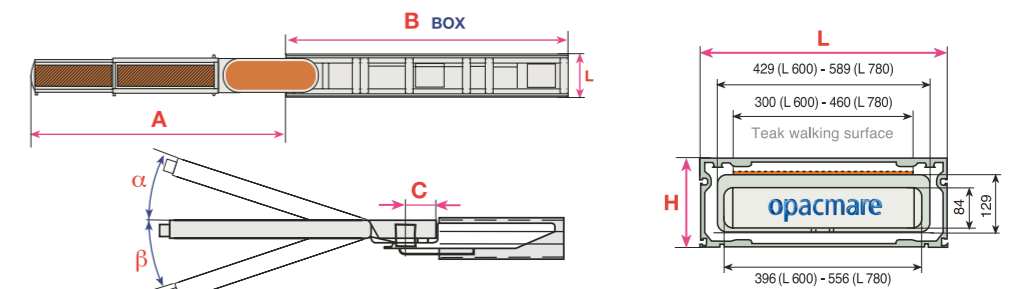

Model Code	A mm	B mm	L mm standard/optional	H mm	C mm	$\alpha$	$\beta$	Rotation	Loading capacity optional kg	Weight kg
MM OPA 1202/29	2860	2800	600/780	290	290	20°	15°	180°	350	605
MM OPA 1202/35	3530	3750	600/780	290	805	15°	15°	180°	-	790
MM OPA 1202/40	4100	3850	600/780	290	890	15°	15°	180°	-	881
MM OPA 1202/52*	5270	4600	600/780	290	890	15°	15°	180°	-	962
MM OPA 1202/57*	5700	5600	780	290	1305	15°	15°	180°	-	1075
MM OPA 1202/80*	8000	8200	780	290	3565	15°	15°	180°	-	1431

This passerelle enables taking the passengers on board but not lifting the tender for a total loading of 150 kg (one person only)

FIND THE NEW PRODUCTS ON LINE  
[www.mansuetomarine.it](http://www.mansuetomarine.it)





RETRACTABLE GANGWAY 1204

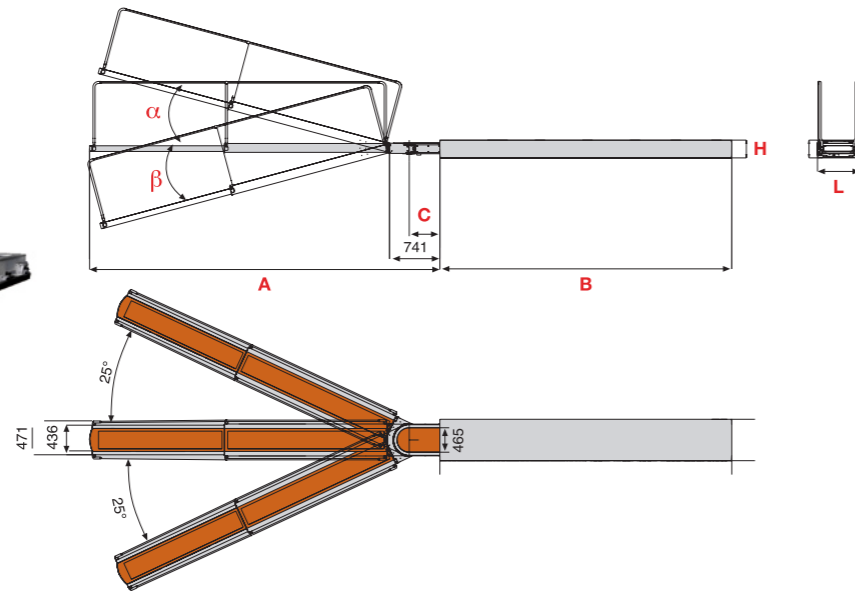
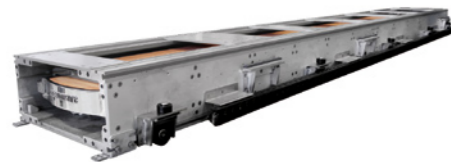

Model Code	A mm	B mm	L mm	H mm	C mm	$\alpha$	$\beta$	Weight kg
MM OPA 1204/52	5160	4400	610	265	450	15°	15°	812

This model enables taking the passengers on board for a total loading of 150 kg



EXTENDING BOX GANGWAY 1402 "MAXI"

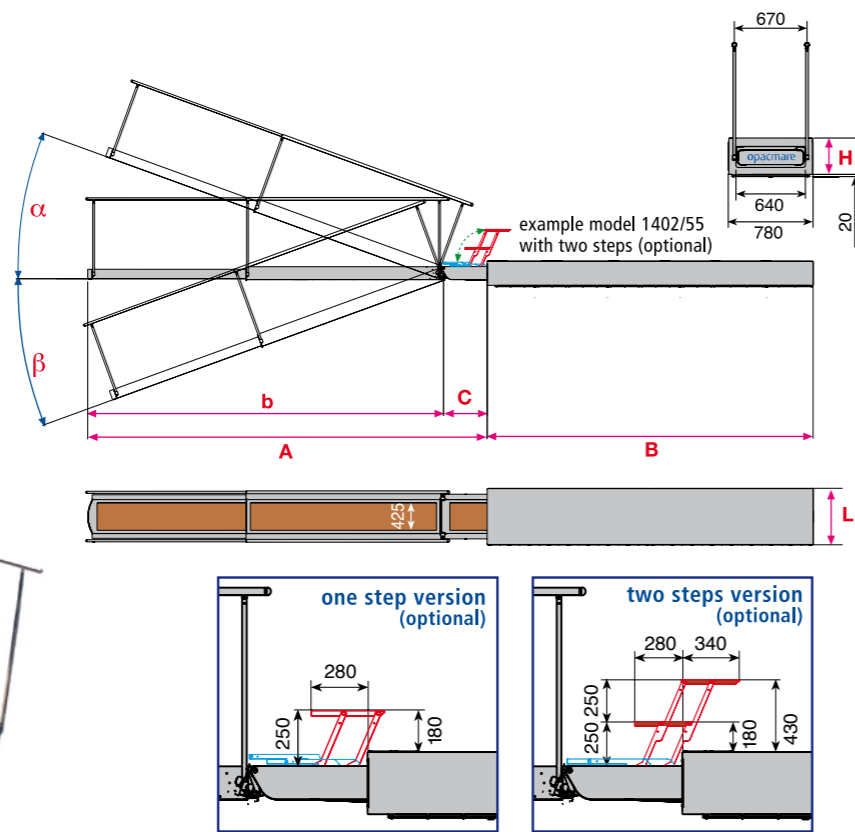

Model Code	A mm	B mm	b mm	L mm	H mm	C mm	$\alpha$	$\beta$	Weight kg
MM OPA 1402/38	3760	3600	3550	780	290	600	20°	20°	798
MM OPA 1402/45	4450	4000	3960	780	290	600	20°	20°	857
MM OPA 1402/55	5510	4500	4915	780	290	600	20°	20°	950

This gangway is for a total loading of 250 Kg



EXTENDING BOX GANGWAY 1424

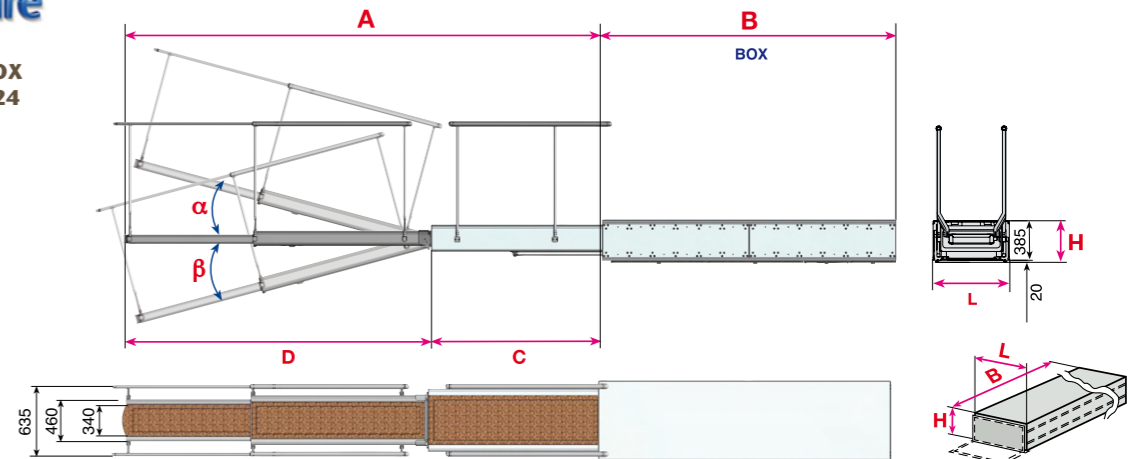
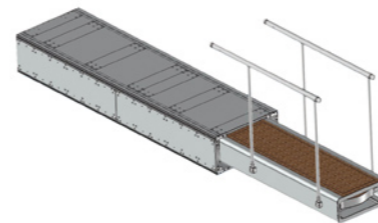

Model Code	A mm	B mm	C mm	D mm	L mm	H mm	$\alpha$	$\beta$	Weight kg
MM OPA 1424/38	3745	2230	1240	2505	750	385	15°	15°	455
MM OPA 1424/43	4315	2430	1440	2875	750	385	15°	15°	488
MM OPA 1424/53	5330	2890	1800	3530	750	385	15°	15°	593
MM OPA 1424/61	6080	3230	2040	4040	750	385	15°	15°	720
MM OPA 1424/66	6590	3570	2180	4410	750	385	15°	15°	840
MM OPA 1424/75	7480	3930	2440	5040	750	385	15°	15°	985

This passerelle enables taking the passengers on board but not lifting the tender for a total loading of 150 kg (one person only)

EASY ORDERS

CUSTOMER CONTACT CENTRE

www.mansuetomarine.it  
+39 0184 573346

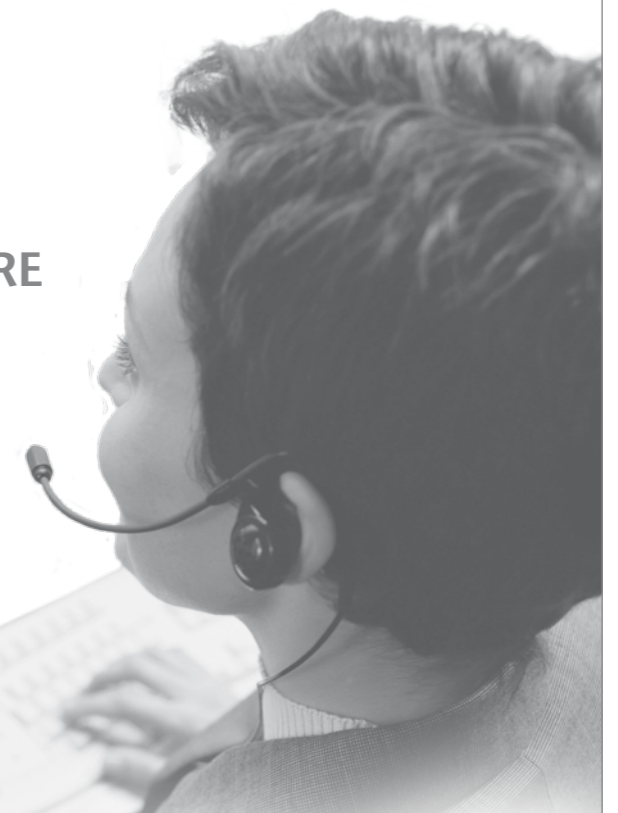



EXTENDING BOX CRANE GANGWAY 1502

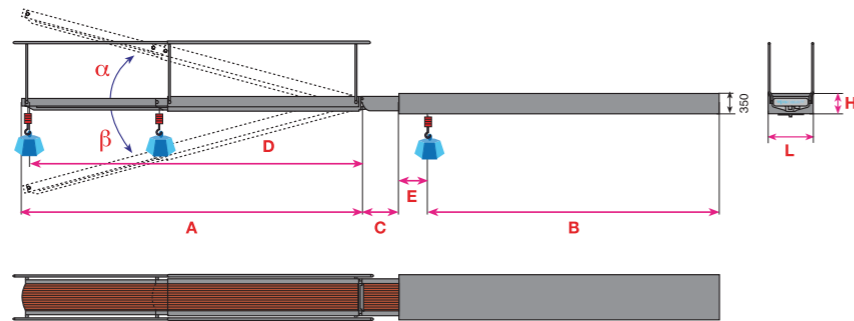

Model Code	A mm	B mm	L mm	H mm	C mm	D mm	E mm	$\alpha$	$\beta$	Cable length mm	Capacity kg	Weight kg
MM OPA 1502/42	4155	3950	780	350	375	3850	475	-	-	2000	450	1333
MM OPA 1502/64	6370	5540	780	350	545	6350	100	-	-	2000	500	1853

Ideal for jet ski and tender lifting.



ROTATING CRANE GANGWAY 1702

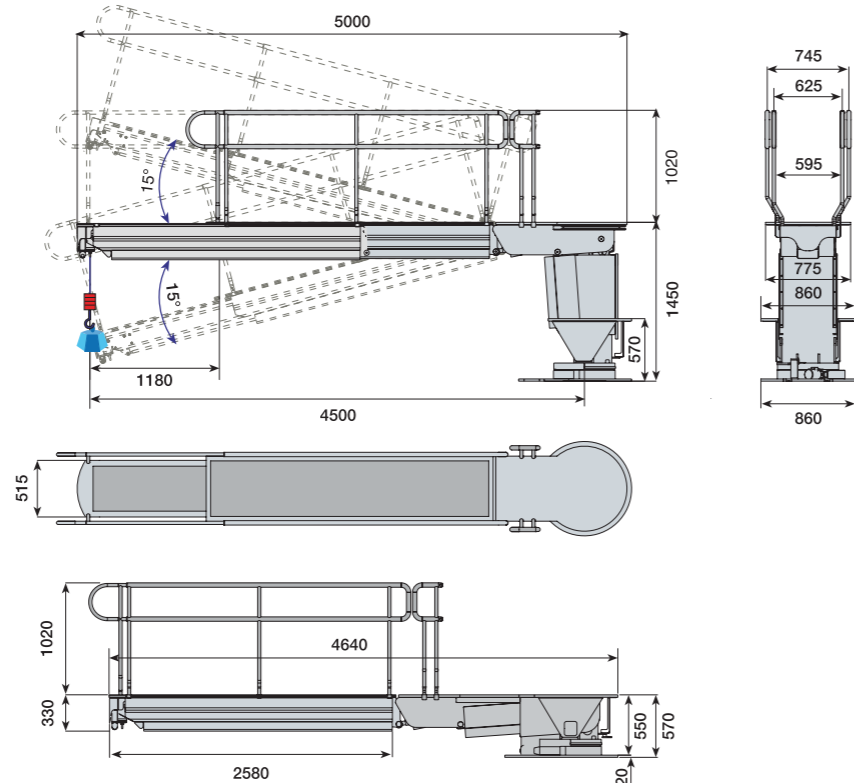

Model Code	Cable length mm	Capacity kg	Weight kg
MM OPA 1702/45	2000	600	1220



ROTATING CRANE GANGWAY 1712

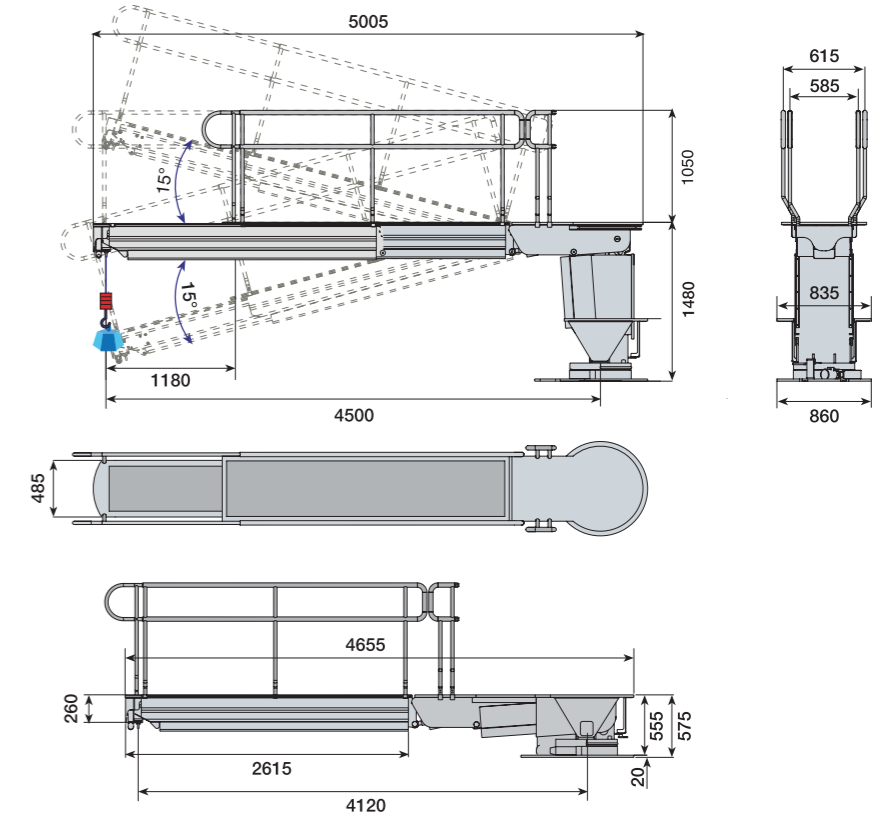

Model Code	Cable length mm	Capacity kg	Weight kg
MM OPA 1712/45	2000	800	1360



ROTATING CRANE GANGWAY 1803

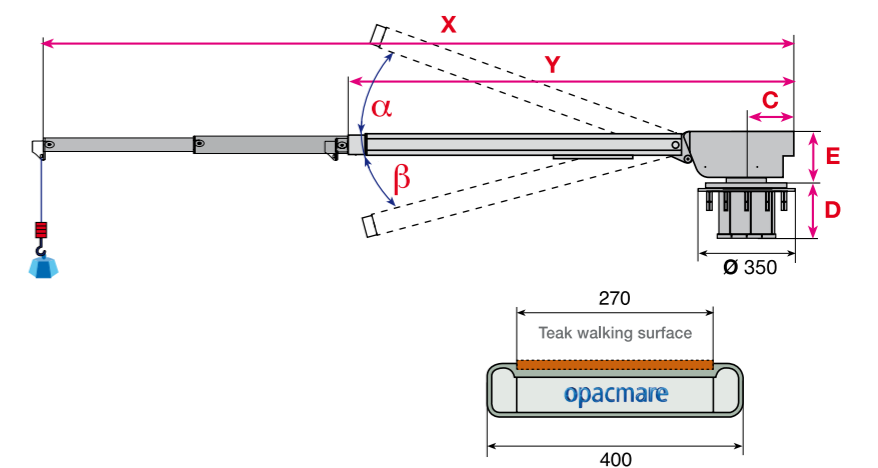

Model Code	X mm	Y mm	C mm	D mm	E mm	$\alpha$	$\beta$	Rotation standard	Rotation optional	Capacity standard kg	Weight kg
MM OPA 1803/38	3730	1930	205	180	225	40°	22°	180°	359°	250	252

This gangway is for a total loading of 150 Kg  
Ideal for tender lifting





**ROTATING CRANE GANGWAY 1802**

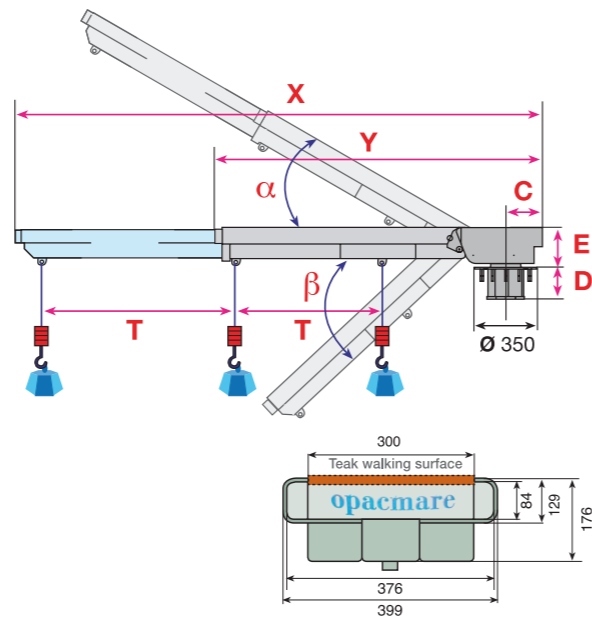

Model Code	X mm	Y mm	C mm	D180° mm	E mm	E350kg mm	T mm	α	β	Rotation standard	Rotation optional	Capacity standard kg	Capacity optional kg	Weight kg
MM OPA 1802/33	3300	2100	205	180	270	-	1235	40°	22°	180°	359°	250	350	291
					-	320		35°	12°					
MM OPA 1802/39	3840	2430	205	180	270	-	1570	40°	22°	180°	359°	250	350	358
					-	320		35°	12°					

This passerelle is for a total loading of 150 Kg  
Ideal for jet ski and tender lifting.



**ROTATING CRANE GANGWAY 1811**

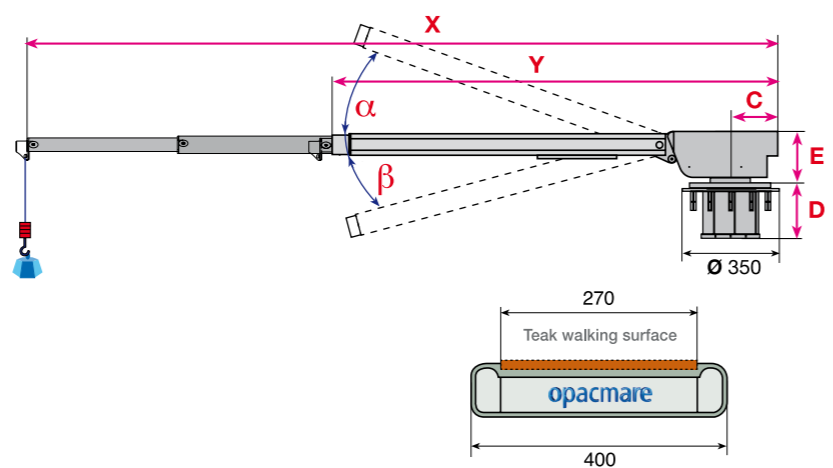

Model Code	α	Rotation standard	Rotation optional	Weight kg
MM OPA 1811/65	30°	180°	359°	1250

This gangway is for a total loading of 150 Kg



**ROTATING GANGWAY 1853**

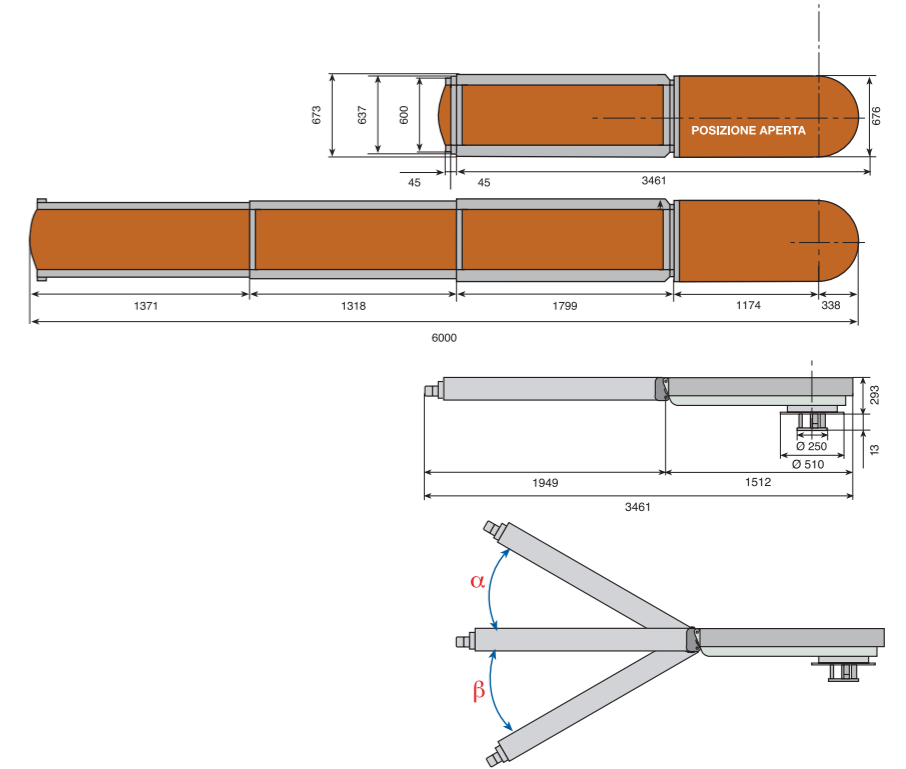

Model Code	α	β	Rotation standard	Rotation optional	Weight kg
MM OPA 1853/60	30°	30°	180°	359°	611

This gangway is for a total loading of 150 Kg



**ROTATING CRANE GANGWAY 1898**

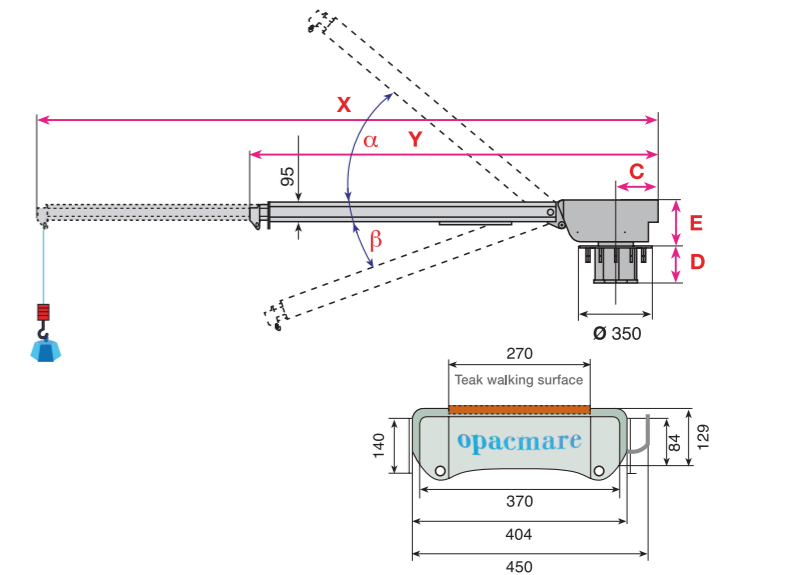

Model Code	X mm	Y mm	C mm	D180° mm	E mm	α	β	Rotation standard	Rotation optional	Capacity standard kg	Capacity optional kg	Weight kg
MM OPA 1898/32	3200	2220	205	180	225	40°	22°	180°	359°	250	350/450	267
MM OPA 1898/39	3930	2490	205	180	320	40°	22°	180°	359°	250	350/450	314

Capacity optional 450 Kg  
Ideal for jet ski and tender lifting



**ALTAIR SINGLE ELEMENT MODEL**

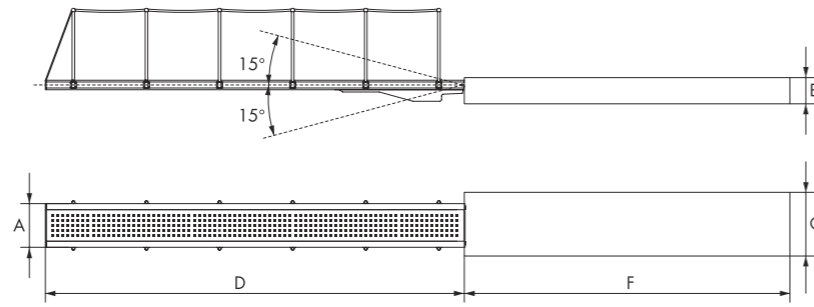

Single element motorized gangway: structure made of anodized light alloy, nature teak grating walking surface, extractable stanchions. Prearranged for operating the flap door. Embed push-button control panel, automatic control of the movements, prearrangement for radio control. Power supply on request.

Code	A mm	B mm	C mm	D mm	F mm	Approx Weight kg
MM SAN 4610000	600	300	730	min 3000 max 4800	min 3800 max 5600	420
MM SAN 4620000	700	360	800	min 4000 max 6000	min 5000 max 7000	580



**ALTAIR TWO ELEMENT MODEL**

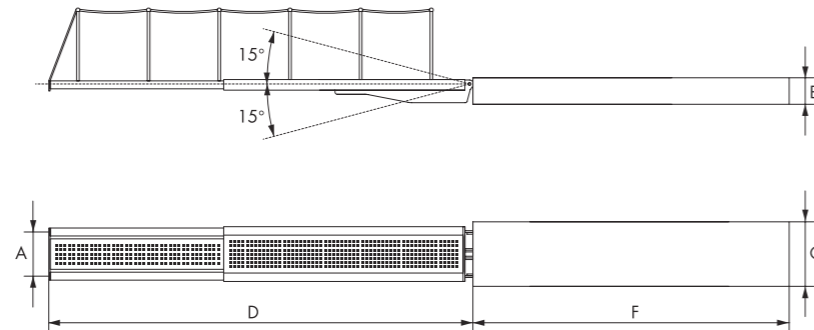
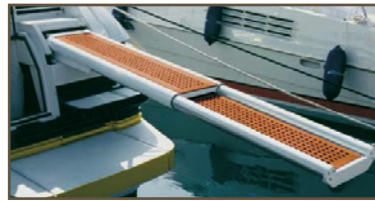

Two element motorized telescopic gangway: structure made of light alloy, nature teak grating walking surface, extractable stanchions. Prearranged for operating the flap door. Embed push-button control panel, automatic control of the movements, prearrangement for radio control. Power supply on request.

Code	A mm	B mm	C mm	D mm	F mm	Approx Weight kg
MM SAN 4613000	500	300	730	min 3500 max 4800	min 2900 max 3660	480
MM SAN 4623000	560	360	800	min 4000 max 6000	min 3250 max 4350	680



**ALTAIR THREE ELEMENT MODEL**

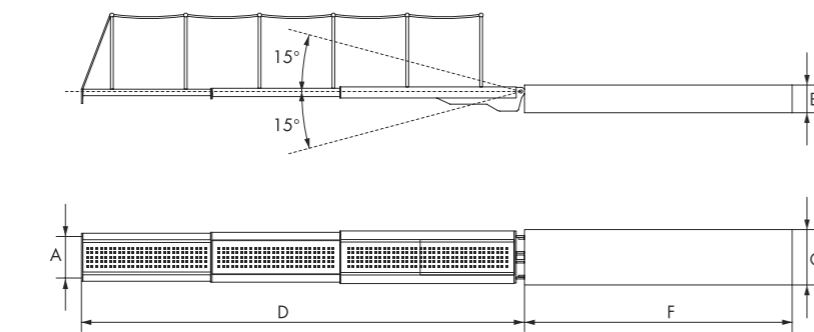
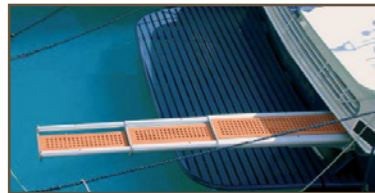

Three element motorized telescopic gangway: structure made of light alloy, nature teak grating walking surface, extractable stanchions. Prearranged for operating the flap door. Embed push-button control panel, automatic control of the movements, prearrangement for radio control. Power supply on request.

Code	A mm	B mm	C mm	D mm	F mm	Approx Weight kg
MM SAN 4616000	500	300	730	min 3500 max 4800	min 2350 max 3100	520
MM SAN 4626000	560	360	800	min 4000 max 6000	min 2700 max 3400	750



**MIZAR SINGLE ELEMENT MODEL**

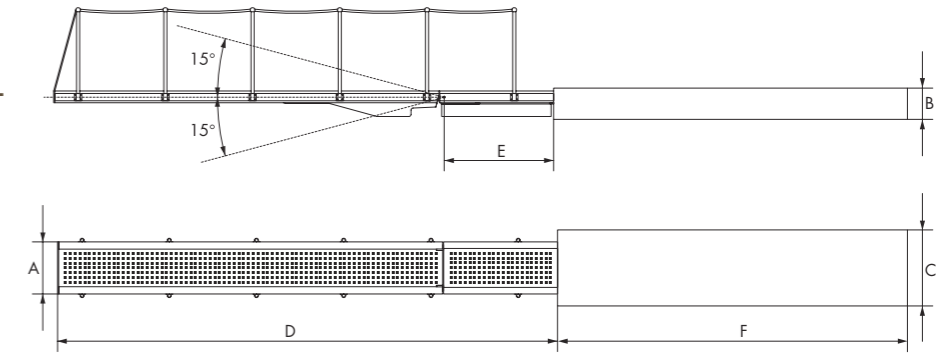

Single element motorized gangway: with inclination axis outer stern, made of anodized light alloy, nature teak grating walking surface, extractable stanchions. Prearranged for operating the flap door. Embed push-button control panel, automatic control of the movements, prearrangement for radio control. Power supply on request.

Code	A mm	B mm	C mm	D mm	E mm	F mm	Approx Weight kg
MM SAN 4630000	600	350	750	min 3500 max 4800	1050	min 4400 max 5800	580
MM SAN 4640000	700	360	800	min 4000 max 6000	1050	min 5000 max 7000	800



**MIZAR TWO ELEMENT MODEL**

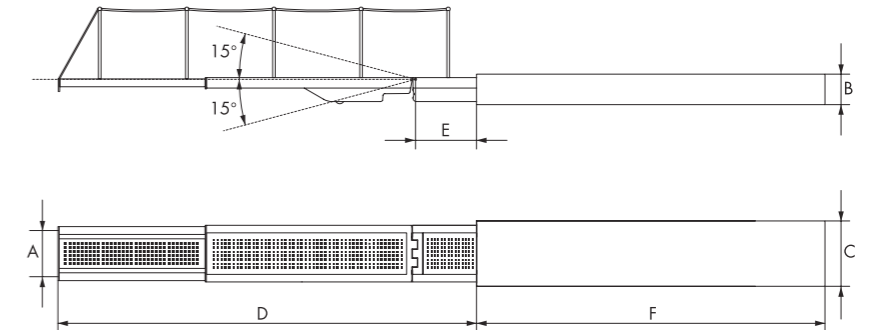

Two element motorized gangway: with inclination axis outer stern, made of light alloy, nature teak grating walking surface, extractable stanchions. Prearranged for operating the flap door. Embed push-button control panel, automatic control of the movements, prearrangement for radio control. Power supply on request.

Code	A mm	B mm	C mm	D mm	E mm	F mm	Approx Weight kg
MM SAN 4633000	530	350	750	min 3500 max 4800	700	min 3400 max 4100	640
MM SAN 4643000	560	360	800	min 4000 max 6000	700	min 3750 max 4750	1000



**MIZAR THREE ELEMENT MODEL**

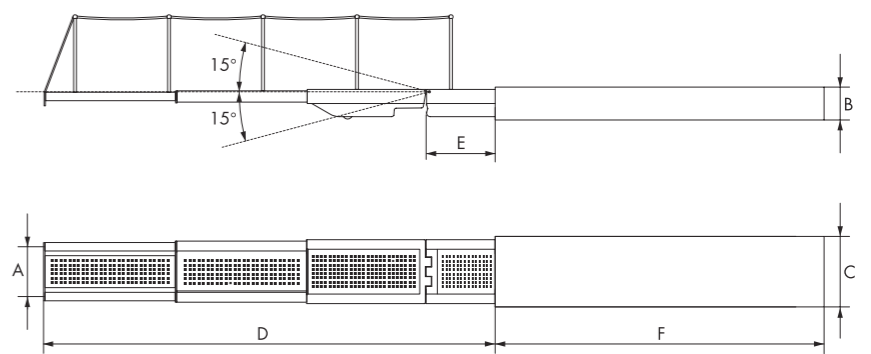

Three element motorized gangway: with inclination axis outer stern, made of light alloy, nature teak grating walking surface, extractable stanchions. Prearranged for operating the flap door. Embed push-button control panel, automatic control of the movements, prearrangement for radio control. Power supply on request.

Code	A mm	B mm	C mm	D mm	E mm	F mm	Approx Weight kg
MM SAN 4636000	530	350	750	min 3500 max 4800	700	min 3250 max 3500	700
MM SAN 4646000	560	360	800	min 4000 max 6000	700	min 3300 max 4100	1000



**SIRIUS SINGLE ELEMENT ROTATING MODEL**

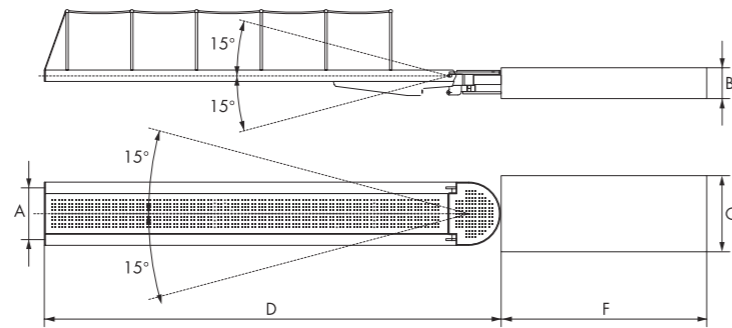

Code	A mm	B mm	C mm	D mm	F mm	Approx Weight kg
MM SAN 4650000	600	350	730	min 3500 max 4000	min 4250 max 4800	480
MM SAN 4660000	680	405	1000	min 4000 max 4800	min 5000 max 5850	850
MM SAN 4670000	680	405	1000	min 5000 max 6000	min 6000 max 7000	900

Single element sideways rotating gangway: made of light alloy, nature teak grating walking surface, extractable stanchions. Prearranged for operating the flap door. Embed push-button control panel, automatic control of the movements, prearrangement for radio control. Power supply on request.



**SIRIUS TWO ELEMENT ROTATING MODEL**

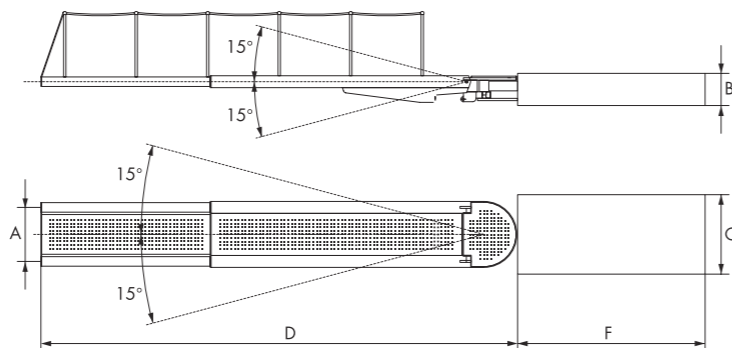

Code	A mm	B mm	C mm	D mm	F mm	Approx Weight kg
MM SAN 4653000	530	350	730	min 3500 max 4000	min 3000 max 3270	530
MM SAN 4663000	680	405	1000	min 4000 max 4800	min 3700 max 4200	1000
MM SAN 4673000	680	405	1000	min 5000 max 6000	min 4300 max 4800	1150

Two element sideways rotating telescopic gangway: made of light alloy, nature teak grating walking surface, extractable stanchions. Prearranged for operating the flap door. Embed push-button control panel, automatic control of the movements, prearrangement for radio control. Power supply on request.



**SIRIUS THREE ELEMENT ROTATING MODEL**

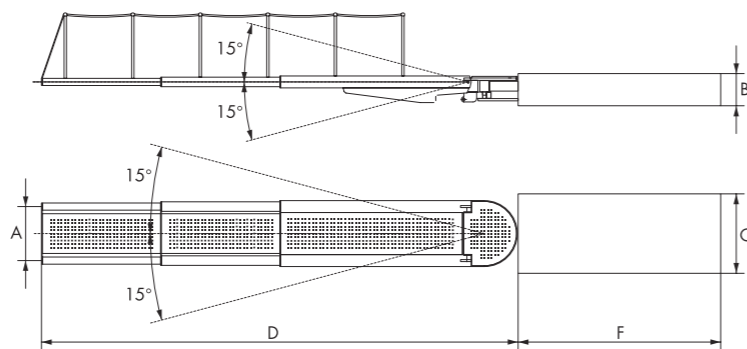

Code	A mm	B mm	C mm	D mm	F mm	Approx Weight kg
MM SAN 4656000	530	350	730	min 3500 max 4000	min 2460 max 2760	590
MM SAN 4666000	680	405	1000	min 4000 max 4800	min 3300 max 3600	1150
MM SAN 4676000	680	405	1000	min 5000 max 6000	min 3700 max 4150	1200

Three element sideways rotating telescopic gangway: made of light alloy, nature teak grating walking surface, extractable stanchions. Prearranged for operating the flap door. Embed push-button control panel, automatic control of the movements, prearrangement for radio control. Power supply on request.



**CRANES & DAVITS**



**HYDRAULIC DAVITS FOR STERN G336 BIG MAGIC**

Code MM BSZ G336

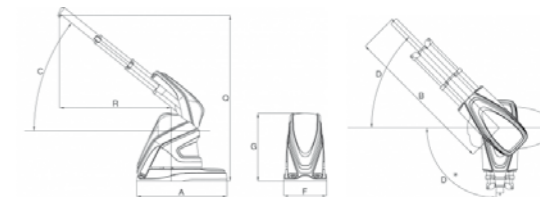

Lifting capacity kg	A mm	B mm	C (°)	D (°)	D* mm	F mm	G mm	Q mm	R mm	Weight kg
500	1070	1800	-35	-45	-90	510	800	1950	1320	185



**HYDRAULIC DAVITS FOR STERN G333**

Code MM BSZ G333

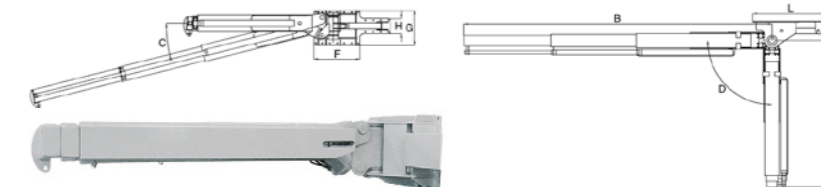

Lifting capacity kg	A mm	B mm	C (°)	D (°)	E mm	F mm	G mm	H mm	L mm	Weight kg	Power supply volt
600	1970	4000	-14	90	250	600	450	200	1000	440	24
400	1800	4100	-20	110	230	320	380	205	720	380	24
300	1700	3800	-20	110	180	320	380	190	610	350	24
150	1365	2760	-19	100	180	350	300	185	610	380	24



**HYDRAULIC DAVITS FOR FLYING BRIDGE G 323 COMMODORE LINE**

Code MM BSZ G323

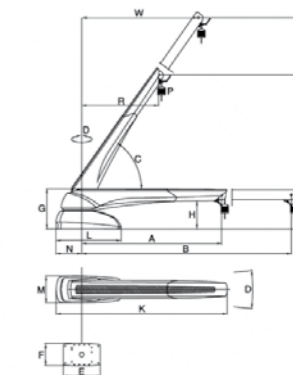

Lifting capacity kg	A mm	B mm	C (°)	D (°)	E mm	F mm	G mm	H mm	K mm	L mm	M mm	N mm	P mm	Q mm	R mm	S mm	W mm	Weight kg	Power supply volt
800	2850	4250	-52	180±270	740	440	810	580	3425	1300(180°) 1470(270°)	550	520	5400	3050	1570	1150	2340	750	12-24

Safety locked included for the version: 800-1000-1200-1500 kg.





**HYDRAULICS DAVITS FOR FLYING BRIDGE G 350 COMMODORE LINE**

Code MM BSZ G350

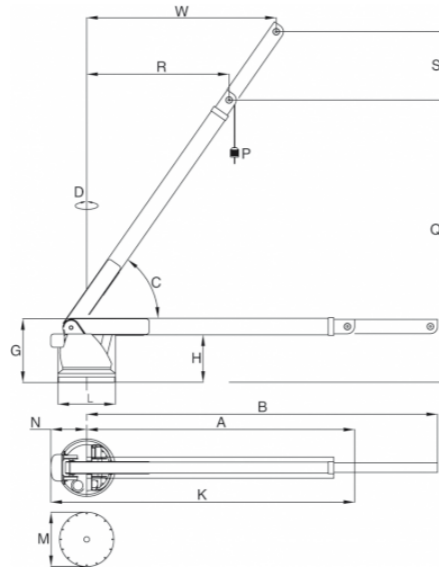

Lifting capacity kg	A mm	B mm	C (°)	D (°)	G mm	H mm	K mm	L mm	M mm	N mm	P mm	Q mm	R mm	S mm	W mm	Weight kg	Power supply volt
1500	4850	6350	-52	180±270	1160	850	5500	1050	Ø980	650	9000	5100	2700	1240	3430	1600	12-24

Safety locked included for the version: 800-1000-1200-1500 kg.



**FLYBRIDGE DAVITS 3023**

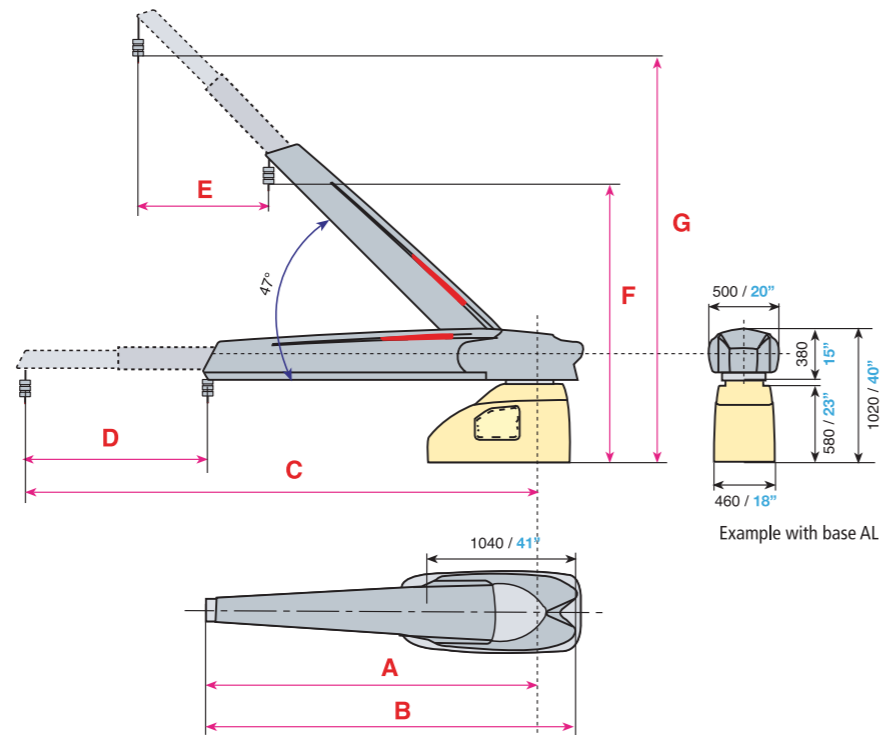

Model	A mm	B mm	C mm	D mm	E mm	F* mm	G* mm	cable length mm	capacity standard Kg	capacity optional Kg	weight Kg
MM OPA 3023/45	2400	2650	4200	1830	1250	1900	3240	5400	500	-	607
MM OPA 3023/51	2800	3050	4850	2050	1350	2250	3700	6200	500	-	680

\*The dimensions F and G are referred to the assembly on AL base



**FLYBRIDGE DAVITS 3088 (FOR RESCUE BOATS)**

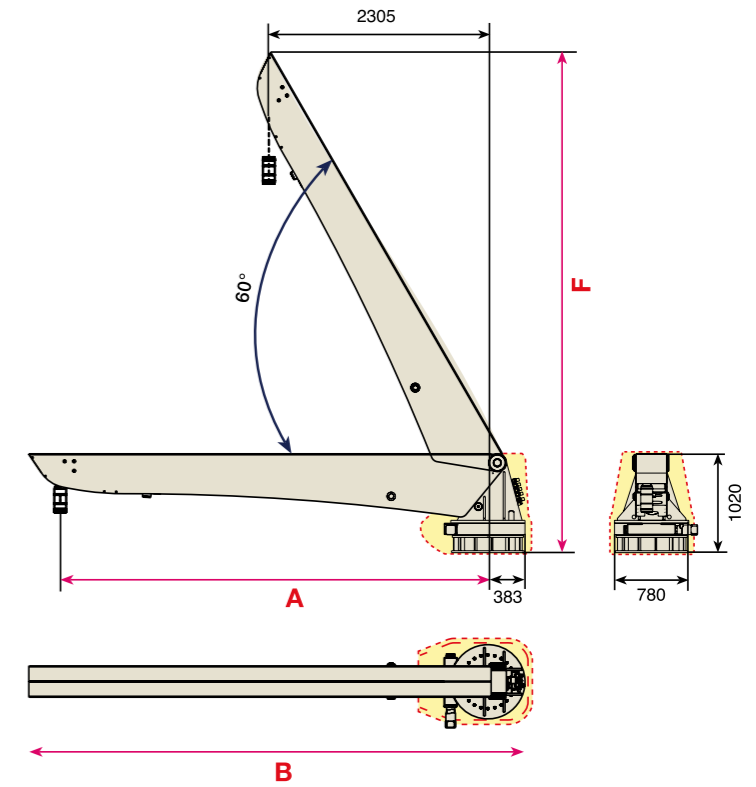

Model	A mm	B mm	F mm	cable length mm	capacity standard Kg	weight Kg
MM OPA 3088/45	4500	5220	5260	7200	3500	2370



**STOWED DAVITS 3048 (FOR RESCUE BOATS)**

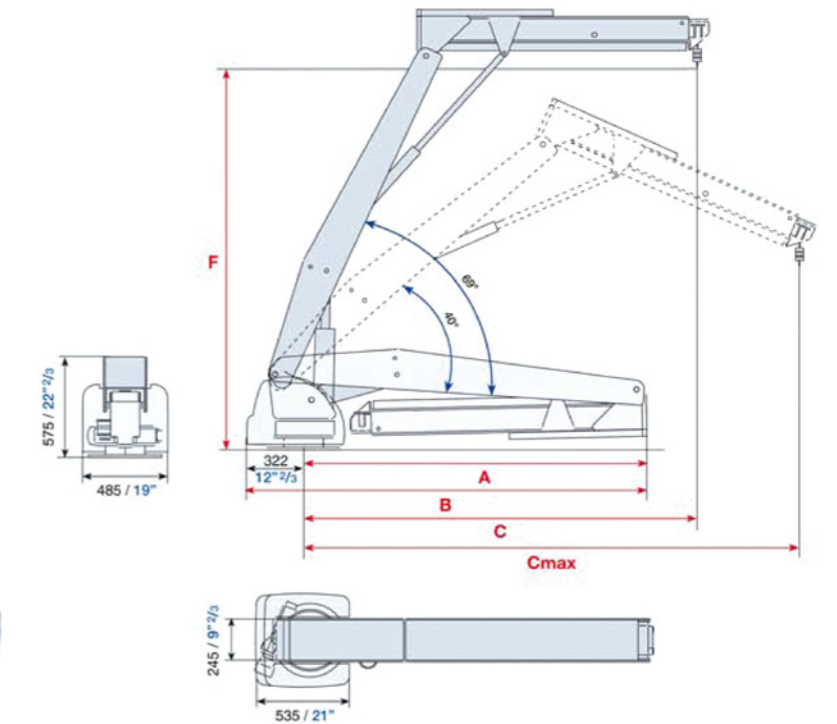

Model	A mm	B mm	C mm	Cmax mm	F mm	cable length mm	loading standard Kg	weight Kg
MM OPA 3048/26	1930	2250	2260	2785	2230	4500	400	404
MM OPA 3048/31	2330	2650	2800	3440	2575	7500	500	431



**STOWED DAVITS 3077  
(FOR RESCUE BOATS)**

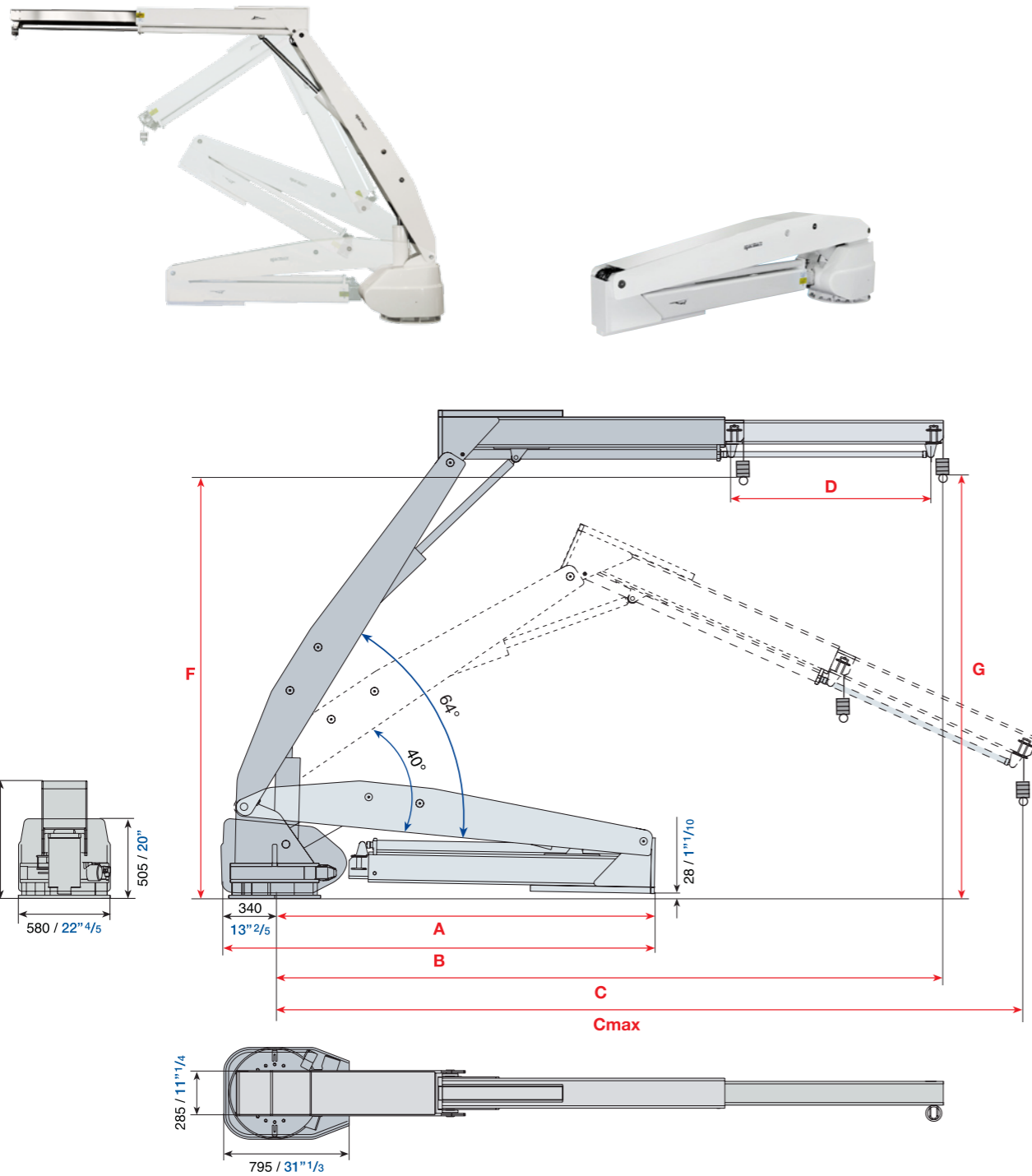

Model	A mm	B mm	C mm	Cmax mm	D mm	F mm	G mm	cable length mm	capacity standard Kg	weight Kg
MM OPA 3077/42	2400	2740	4225	4800	1260	2800	2800	5400	1000	950

For this crane model, the optional configuration with fixed base and rotating turret is also available



**FLY BRIDGE CRANE**

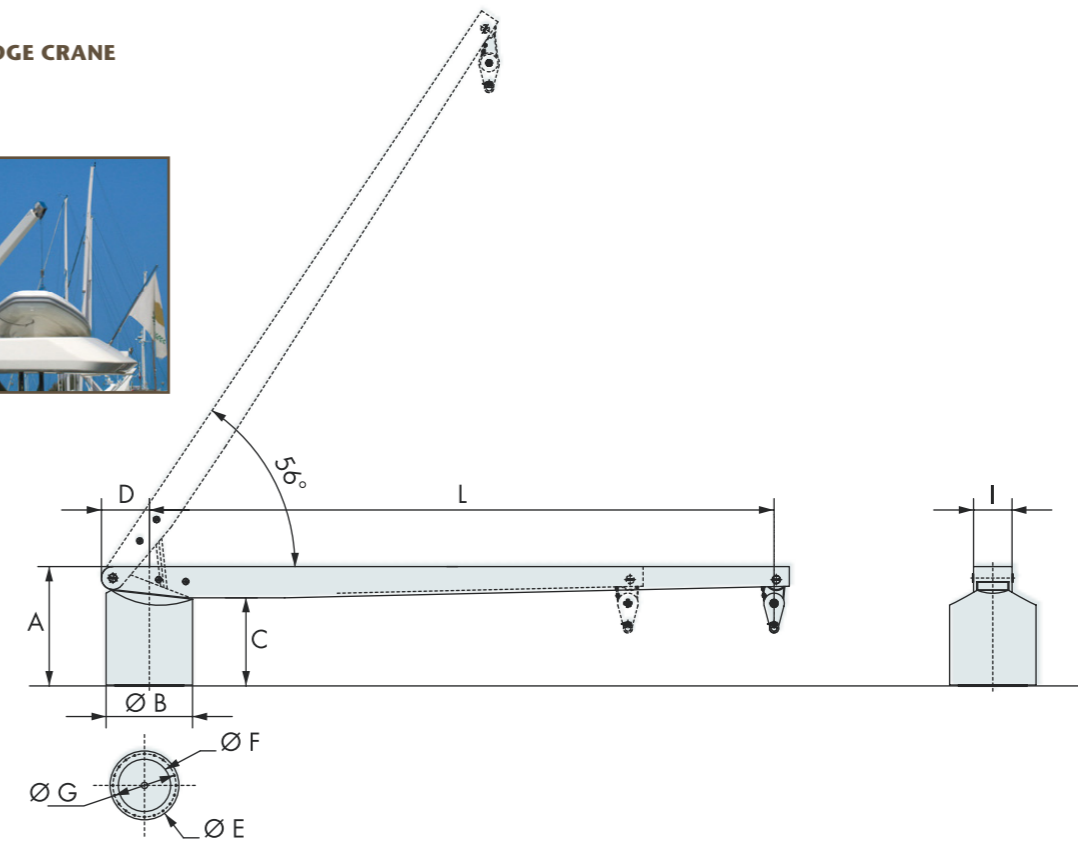

Code	Max Load Kg	Feeding Volt	Power Watt	A mm	BØ mm	C mm	D mm	EØ mm	FØ mm	GØ mm	I mm	L Max mm	Boom Type	Weight Kg
MM SAN 5406100	1500	230/400 3PH	5000	1150	830	850	460	660	600	N°20 holes	370	5000	Rigid	1420
MM SAN 5406100TI	1500	230/400 3PH	5000	1150	830	850	460	660	600	Ø17,5 on Ø 605	370	5000	Telescopic	1570
MM SAN 5407100	2000	230/400 3PH	5000	1150	830	850	460	660	600		370	6000	Rigid	1550
MM SAN 5407100TI	2000	230/400 3PH	5000	1150	830	850	460	660	600		370	6000	Telescopic	1700

**AUTHORIZED SERVICE STATION**  
for Besenconi, Opacmare, Sanguineti and Atlas  
Supplies, Repairs, Testing, Spare Parts, Installations

**LOAD AND MOB TESTS**  
Logistic support, Weights and Rescue Boat rental, Assistance

**SURVEYORS SUPPORT**  
Certified consulting, Day workers, Tools and Services



**DECK CRANE  
(FOR RESCUE BOATS)**

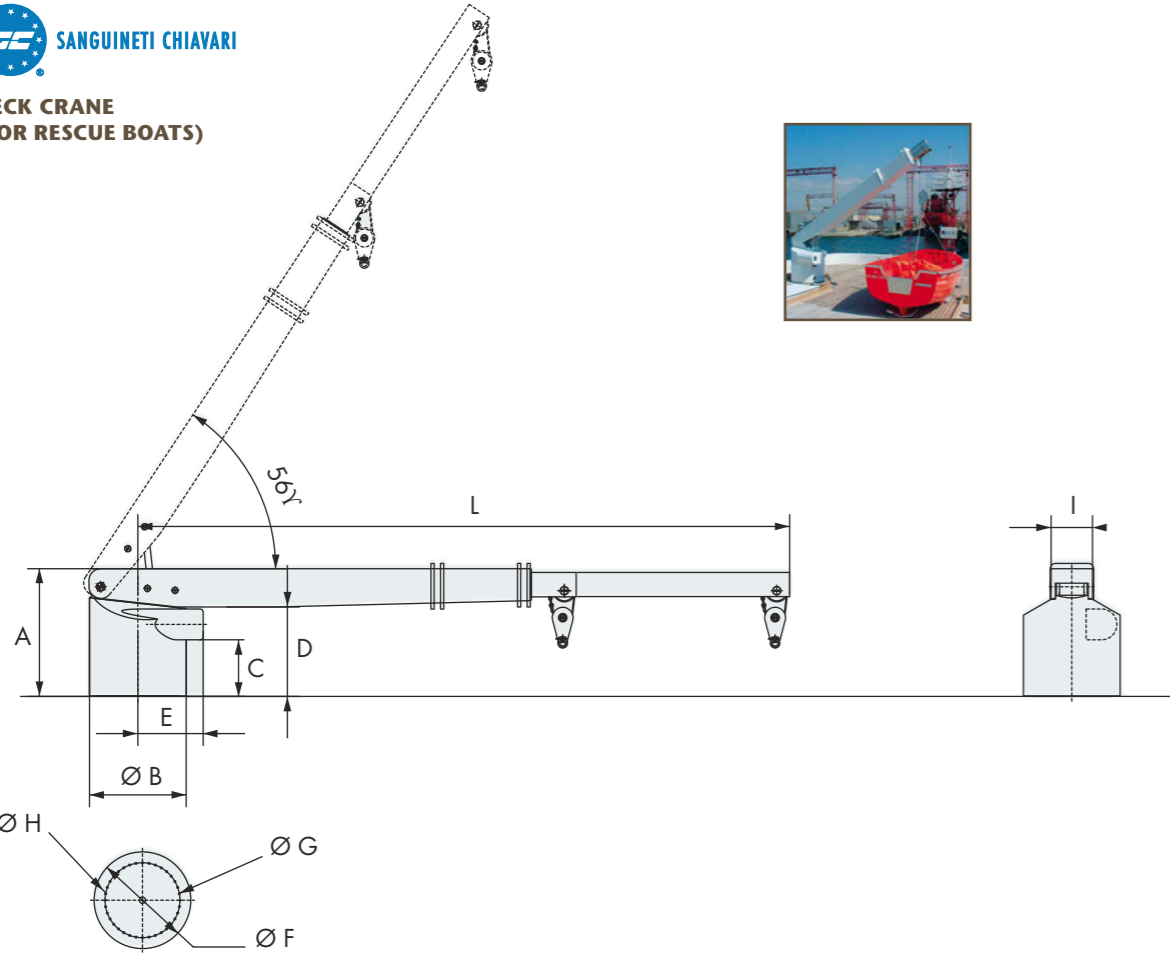

Code	Max Load Kg	Feeding Volt	Power Watt	A mm	B Ø mm	C mm	D mm	E mm	F Ø mm	G Ø mm	H mm	I mm	L mm	Weight Kg
MM SAN 5407600	2000	400 3PH	10000	1200	910	500	840	615	850	N° 36 holes Ø 17 on Ø 705	765	390	4000+2000	1700



**ATLAS CARBON DAVITS**



- Socket depth in deck: 450 mm / 18 in
- Socket internal diameter GRP and Aluminium: 152 mm / 6 in
- Socket internal diameter stainless steel: 154 mm / 6 in
- Manual winch (with 5:1 purchase)
- Electric winch 12/24 volt
- Bearing plain polyester
- Construction Advanced Pre-preg carbon fibre

Code	Standard Stem mm	Short Stem mm	Manual Kg	Electric Kg
MM ALS 1200	1350	1150	19 SHORT 18	23 SHORT 23
MM ALS 1600	1550	1200	23 SHORT 20	28 SHORT 27
MM ALS 2000	1650	1350	29 SHORT 28	35 SHORT 34

MANSUETO MARINE



**ACCESSORIES**



Atmosphère

**SALGOBENE COMFORT ART 46**

Code: MM ATP COM46

Two-Step with handles and peak  
Measures mm 600 x 525 x 480 h



**SALGOBENE MINI ART 48**

Code: MM ATP MIN48

One-Step  
Measures mm 360 x 600 x 250 h



**Teak custom steps  
with shoes compartement  
available on request**



**TELESCOPIC LADDER**



Code	MM TLS 60233	MM TLS 60838
Tread width	65 mm	65 mm
Working height	4,4 mt	5,0 mt
Length, extended	3,3 mt	3,8 mt
Length, closed	78 cm	110 cm
Width	49 cm	51 cm
Weight	10,7 kg	12,8 kg



Osculati

**JACK LADDER**

Made of blue nylon cord,  
fitted with polycarbonate  
steps.



Code	Version	Length cm	Steps cm	Rope Ø mm
MM OSC 4952403	3 steps	94	30x11x4	12
MM OSC 4952404	4 steps	114	30x11x4	12
MM OSC 4952405	5 steps	134	30x11x4	12

www.mansuetomarine.it





**EMBARKATION LADDERS**

Wooden steps.  
Approved MED-SOLAS.



Code	Length
MM VIK 1026189	3 metres
MM VIK 1026193	4 metres
MM VIK 1026188	5 metres
MM VIK 1039891	6 metres
MM VIK 1026191	8 metres
MM VIK 1022380	10 metres
MM VIK 1020998	12 metres
MM VIK 1020999	14 metres
MM VIK 1021000	16 metres
MM VIK 1021002	18 metres
MM VIK 1021003	20 metres
MM VIK 1026205	22 metres
MM VIK 1029732	27 metres

**PILOT LADDERS**

Wooden steps.  
Approved MED-SOLAS.



Code	Length
MM VIK 1022435	4 metres
MM VIK 1026212	5 metres
MM VIK 1010434	6 metres
MM VIK 1020995	7 metres
MM VIK 1020996	8 metres
MM VIK 1010435	9 metres
MM VIK 1026217	10 metres
MM VIK 1023814	18 metres

**Custom ladders available  
on request**

ALL OUR PRODUCTS  
ARE DISTRIBUTED IN EVERY  
**CAPTAIN MARINE STORE**

[www.captainmarine.it](http://www.captainmarine.it)  
Find your nearest **CMS**

